

Cover-Up Equipment

Warranty - Material

Hubbell Power Systems, Inc. warrants all products sold by it to be merchantable (as such term is defined in the Uniform Commercial Code) and to be free from defects in material and workmanship. Buyer must notify the Company promptly of any claim under this warranty. The Buyer's exclusive remedy for breach of this warranty shall be the repair or replacement, F.O.B. factory, at the Company's option, of any product defective under the warranty which is returned to the Company within one year from the date of shipment. NO OTHER WARRANTY, WHETHER EXPRESS OR ARISING BY OPERATION OF LAW, COURSE OF DEALING, USAGE OF TRADE OR OTHERWISE IMPLIED, SHALL EXIST IN CONNECTION WITH THE COMPANY'S PRODUCTS OR ANY SALE OR USE THEREOF. The Company shall in no event be liable for any loss of profits or any consequential or special damages incurred by Buyer. The Company's warranty shall run only to the first Buyer of a product from the Company, from the Company's distributor, or from an original equipment manufacturer reselling the Company's product, and is non-assignable and non-transferable and shall be of no force and effect if asserted by any person other than such first Buyer. This warranty applies only to the use of the product as intended by Seller and does not cover any misapplication or misuse of said product.

Warranty - Application

Hubbell Power Systems, Inc. does not warrant the accuracy of and results from product or system performance recommendations resulting from any engineering analysis or study. This applies regardless of whether a charge is made for the recommendation, or if it is provided free of charge.

Responsibility for selection of the proper product or application rests solely with the purchaser. In the event of errors or inaccuracies determined to be caused by Hubbell Power Systems, Inc., its liability will be limited to the re-performance of any such analysis or study.

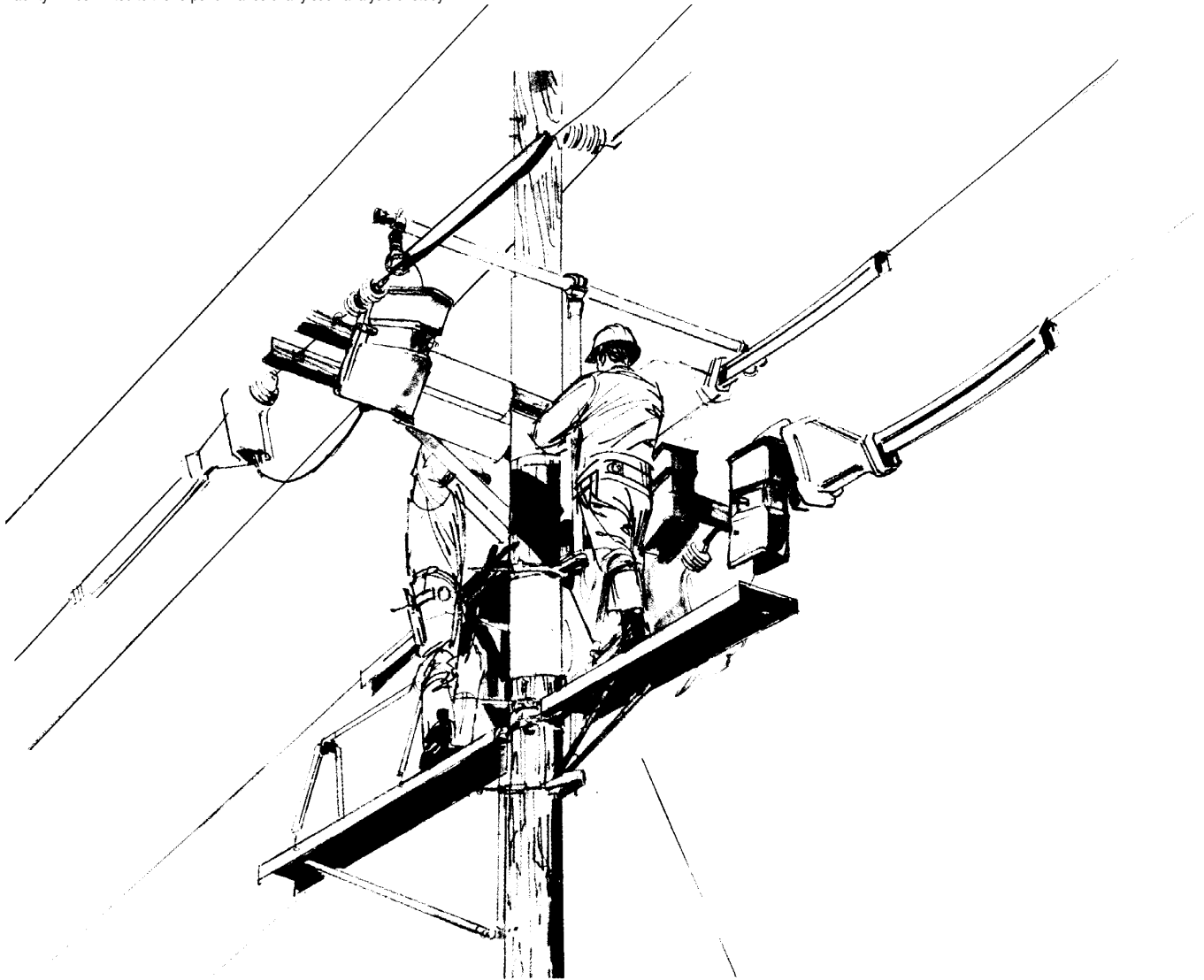

NOTE: Because Hubbell has a policy of continuous product improvement, we reserve the right to change design and specifications without notice.

©Copyright 2007 Hubbell Incorporated • 210 North Allen Street • Centralia, MO 65240

! WARNING

Cover-up equipment, by necessity, is designed to be as universal as possible. Therefore it is possible, as examples, for (1) a tie wire to touch a potentially grounded pin or other part, (2) a person's hand to touch the conductor through an opening in the equipment, or (3) a part of a person's body or other work equipment to contact the conductor through an opening in the cover-up equipment or "in the vicinity of junctions between pieces of cover-up equipment." These possibilities, as well as other possible contacts, do exist, and the persons using this equipment must be aware of them and consider them on each and every application. Necessary precautions must be taken to prevent these contacts. Under no circumstances is Chance cover-up equipment intended to prevent mechanical equipment from contacting either energized or grounded surfaces.

Cover-Up Equipment

Cover-up equipment is finding increasing usage on all types of high-voltage line maintenance. Most of the individual pieces can be installed with rubber gloves, or else they are equipped with hot stick application eyes. Common sense rules must always be followed when using cover-up equipment. These rules include:

1. Cover-up equipment (such as line covers, insulator covers, cutout covers, and deadend covers) is intended to prevent personnel from making accidental brush contact with energized parts or equipment. Under no conditions should personnel purposely contact the covers, except with adequate rubber gloves, and personnel must always be aware of their position in order to avoid accidental contact with the cover.
2. Cover-up equipment (such as pole covers, crossarm guards, crossarm end covers, and pole top covers) is intended to help prevent accidental contact of energized tie wires or conductors with the grounded surface of the pole or crossarm.
3. Cover-up equipment must be handled with care to minimize breakage and scratching, and it must be kept clean. Maintenance is as important with cover-up equipment as with hot line

tools. Each cover must be thoroughly inspected before each use to ensure that it has no cracks, deep scratches, or gouges and to ensure that it is clean. Cleaning should be done with a wiping cloth, and if that does not remove all dirt, mild soap and water should be used. Polyethylene covers can be cleaned with Chance Moisture-Eater II (U.S. Patent 5,405,547) solvent-cleaner (see Catalog Section 2500). **Caution:** Solvents must be avoided unless the user can determine that the material in the particular cover is polyethylene.

4. For Temporary Use — Cover-up equipment is designed to be as light and easy to use as possible, hence it is not made from materials that can withstand extended periods of electrical stress. Therefore, Chance cover-up equipment must not be left installed for extended periods, especially if allowed to touch both an energized surface and a possibly grounded surface. The situation would be highly aggravated in rainy or humid weather, when the surfaces of the covers become dirty, etc. Therefore, the covers should be removed at the end of the workday, if at all possible.

- Tested to ASTM F712.
- Manufactured to ASTM F968 specifications.

This cover aids in the protection of linemen working near most open-type cutouts rated at 25kV or under, but it will not fit over cutouts with linkbreak levers or similar devices. It can be placed over the cutout, and then a locking pin slips behind the cutout insulator over the hanger bracket and into a hole on the opposite side of the cover.

Eyes on both the cover and locking pin allow installation with a Grip-All clampstick.

This cover is made of orange high-impact ABS plastic. Several units can be nested together for convenience and space saving on the truck.

Catalog No.	Description	Weight
C4060009	Cutout Cover with Locking Pin	4 lb./1.8 kg.

- Tested to ASTM F712.
- Manufactured to ASTM F968 specifications.

This cover is made of orange linear polyethylene and is designed to fit over a maximum of two 10-inch diameter deadend insulators. The end of the cover will mate with Chance 25kV conductor covers or rubber line hose to extend the protected area. The cover measures 34 inches in length, 11 inches wide and 12½ inches from the conductor to the bottom of the unit.

The split unit fits easily over the conductor and insulators, yet it can be tightly clamped together using the large hot stick clamp pin, which is similar to those used in securing rubber blankets. A Grip-All adapter (included) allows the unit to be installed with a clampstick, or it can be placed into position with rubber gloves and sleeves when work practices permit.

Catalog No.	Description	Weight
C4060164	Deadend Cover	5 lb./2.3 kg.

Cutout Covers 25 kV Phase-to-Phase



C4060009

Deadend Covers 25 kV Phase-to-Phase

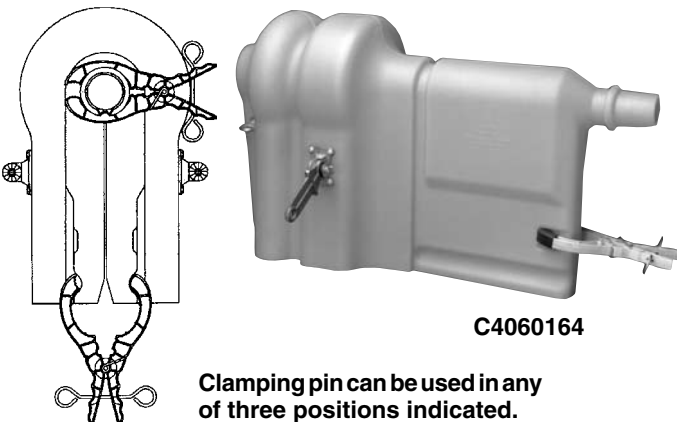

C4060164

Clamping pin can be used in any of three positions indicated.

Conductor and Insulator Covers

25 kV Phase-to-Phase (for 36.6 kV Phase-to-Phase conductor covers, see page 2405)

• Tested to ASTM F712 • Manufactured to ASTM F968 specifications

These covers provide a highly versatile system of covering up a wide variety of configurations on distribution systems. The conductor and insulator units mate together to cover pin-type or post-type insulator construction and also can be used with the deadend cover, shown on page 2402. The units virtually surround the hot parts and hardware to give the linemen extra protection when rubber gloving or using hot sticks.

Both the conductor and insulator cover will couple with major brands of rubber line hose and insulator covers of the 25kV class.

Conductor and insulator covers are made of high-density polyethylene and are bright orange in color.

Conductor covers are 5 feet long and are available with a Grip-All adapter for hot stick application or without adapter for rubber glove application. Also available with 4-foot Epoxiglas® handles. Maximum conductor size: 666 kcmil ACSR.

Insulator covers are 21 inches long and 8½ inches wide and are available in two heights: 6 inches and 9 inches from conductor to cover base to fit different size insulators, either with Grip-All adapter for hot stick application or without adapter for rubber glove application.

Catalog No.	Description	Weight
C4060181	5' Conductor Cover with 4' Epoxiglas Handle	5 lb./2.3 kg.
P4060184	5' Conductor Cover without Adapter or Handle	3 lb./1.4 kg.
C4060181GA	5' Conductor Cover with Grip-All Adapter	4 lb./1.8 kg.
C4060182	Insulator Cover — 6" with Grip-All Adapter	3 lb./1.4 kg.
P4060185	Insulator Cover — 6" without Grip-All Adapter	2½ lb./1.1 kg.
C4060182L	Insulator Cover — 9" with Grip-All Adapter	4 lb./1.8 kg.
P4060186	Insulator Cover — 9" without Grip-All Adapter	3½ lb./1.6 kg.



C4060181GA with Grip-All Adapter



P4060184 without Grip-All Adapter for rubber glove application

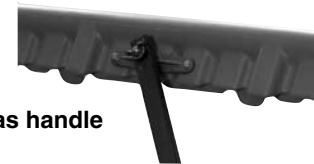

C4060181 with 4-foot Epoxiglas handle



C4060182 and C4060182L with Grip-All Adapter

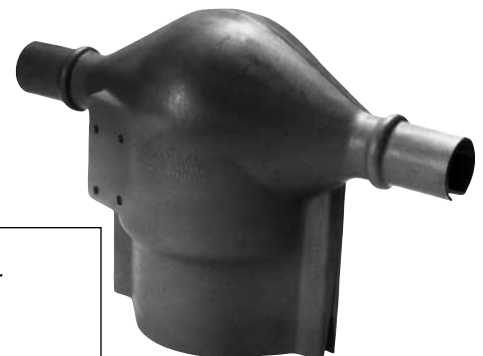

P4060185 and P4060186 without Grip-All Adapter for rubber-glove application

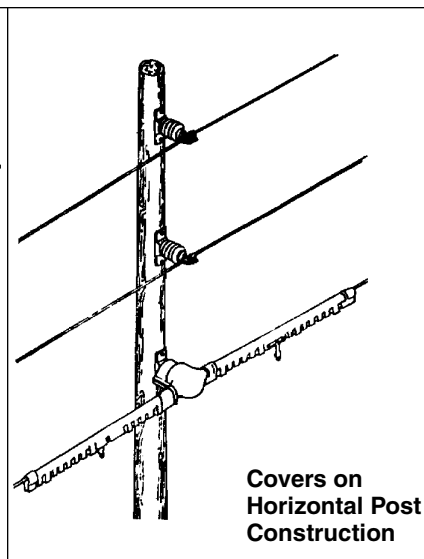
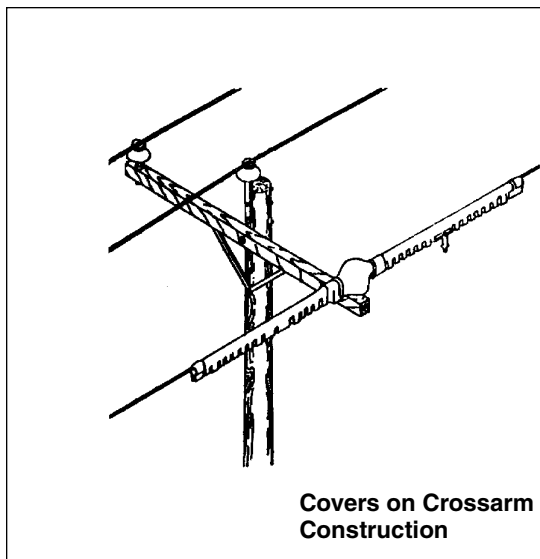

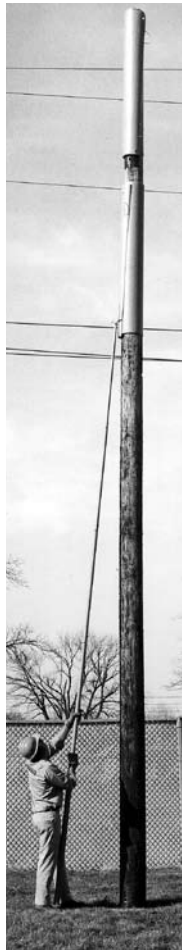

Pole covers can be removed easily from ground level using Chance telescoping tools.

Pole Covers

36.6 kV Phase-to-Phase

- Tested to ASTM F712
- Manufactured to ASTM F968 specifications
- Meet Class 4 requirements

These pole covers are used to help protect personnel when raising or lowering a pole between energized lines or to cover poles when rubber glove maintenance is performed in relatively confined areas. The covers are made of high-dielectric linear polyethylene material that will not flash flame. This material will have some softening without deformation at approximately 170°F, and it will resist brittleness at temperatures to -50°F. All Chance pole covers are ribbed to reduce cover contact with the pole, thus minimizing creosote contamination.

A nylon button on 4- and 6-foot lengths allows the pole covers to be joined together in tandem, where longer lengths require covering. The rope handles permit personnel to easily spread the covers and snap them around the pole; rubber gloves must be worn during this procedure.

Prolonged contact with an energized conductor must not be allowed.

Catalog No.	Overall Length	Weight
6" Diameter Pole Covers		
C4060550	48" overall length	6½ lb. / 3 kg.
C4060551	72" overall length	9½ lb. / 4½ kg.
9" Diameter Pole Covers		
M49371	12" long	2½ lb./1.1 kg.
M49372	24" long	4 lb./1.8 kg.
M49374	48" long	9 lb./4.1 kg.
M49376	72" long	13 lb./5.9 kg.
12" Diameter Pole Covers		
C4060029	24" long	5½ lb./2.5 kg.
C4060030	48" long	11 lb./5.0 kg.
C4060000	72" long	16 lb./7.2 kg.

Rope Lock Assembly

- For securing pole covers on metal, concrete, composite or wood poles
- U.S. Patent 6,070,305



C4060547
Rope Lock Assembly

To help keep pole covers in place, especially on smooth surfaces, this device is easy to place and remove. It may be applied midway and/or as a lower support for pole covers. Instructions are included with each unit for simple installation by hand and removal from ground level with a hot stick.

Catalog No.	Description	Weight
C4060547	Rope Lock Assembly	1½ lb. / 0.75 kg.
C4060564	Replacement rope, ½" x 7 ft.	½ lb. / 0.25 kg.

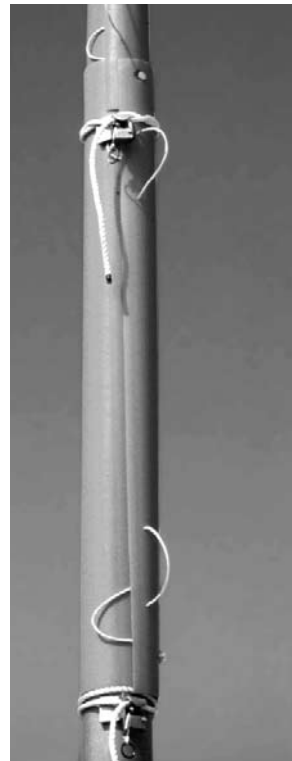

Covers for Conductor, Insulators and Deadends

- 36.6 kV Phase-to-Phase
- ASTM Class 4
- Tested to ASTM F712
- Manufactured to ASTM F968 specifications

These covers provide a highly versatile system of covering up a wide variety of configurations on distribution systems. The conductor covers couple with the insulator units and deadend units to cover pin-type or post-type insulator construction. Together, they virtually surround the hot parts and hardware to give lineworkers extra protection when rubber gloving or using hot sticks. Each item is fitted with an adapter for multi-position handling by Grip-All clampsticks.

These covers also couple with Chance 25 kV covers (catalog pages 2402 and 2403), Classes 2, 3 and 4 of rubber line hose (pages 2410 and 2411) and major brands of rubber insulator hoods.

All covers are bright orange in color. All are made of of high-density polyethylene in a uniform wall thickness for excellent dielectric/puncture strength and perform well from -50° to 170°F. Ultra-violet stabilizers in the material help inhibit degradation as a result of atmospheric exposure.

Conductor cover is 5 feet long. The cover's V-shaped bottom edge makes it easy to install. Four indented ribs along the cover's top edge provide an air gap between the conductor and the cover. Maximum conductor size is 666 kcmil ACSR.

Insulator covers come in two heights. Either 12" or 16½" tall cover fits 6½" to 9"-diameter pin or post insulators. Special slits in the insulator covers help locate the conductor and hardware when installing the covers.

Deadend cover fits three 10"-diameter porcelain bells or polymer deadend insulators and couples with the line cover. To meet the Class 4 rating, the deadend cover must be used in conjunction with a rubber insulating blanket covering the coupler to the line cover. Failure to use a blanket to cover the coupler may result in electrical shock, severe injury or death by electrocution.

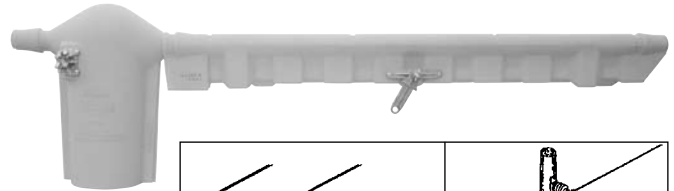

Insulator Cover couples with Conductor Cover using Hot Sticks or Rubber Gloves

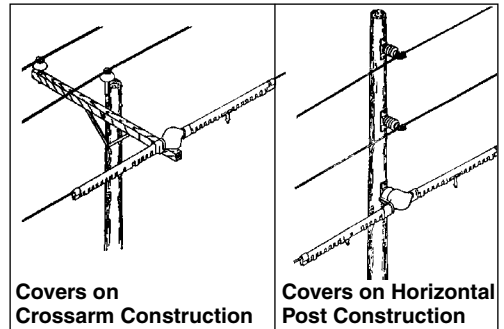

Deadend Cover couples with Conductor Cover

To meet the Class 4 rating, the deadend cover must be used in conjunction with a rubber insulating blanket covering the coupler to the line cover. Failure to use a blanket to cover the coupler may result in electrical shock, severe injury or death by electrocution.



Catalog No.	Description	Weight
C4060514GA	5 ft. Conductor Cover	5¼ lb./2.36 kg.

Conductor cover is 5 feet long and includes an adapter for handling by Grip-All clampsticks.

Maximum conductor size: 666 kcmil ACSR.

C4060557	12" Insulator Cover	3 lb./1.36 kg.
C4060557L	16½" Insulator Cover	3½ lb./1.6 kg.

Insulator covers fit 6½" to 9"-diameter pin or post insulators. Each cover includes an adapter for handling by Grip-All clampsticks.

C4060537	Deadend Cover	5¼ lb./2.36 kg.
----------	---------------	-----------------

Deadend cover fits three 10"-diameter porcelain bells or polymer deadend insulators and includes an adapter for handling by Grip-All clampsticks.

Substation and Underground Barriers

The same excellent quality bright-orange linear polyethylene material as used in many pieces of Chance cover-up equipment is also available in 4- x 6-foot sheets for use in substations and as underground barriers. Cutting smaller pieces is accomplished with any hand or power saw used to cut wood; forming the sheets may be accomplished with a blow torch or in an oven heated to 250°F.

Although the sheet becomes increasingly stiff as temperatures drop, it does not become brittle and break at -50°F, and it will not soften or deform at 170°F. The material will not flash flame. Puncture strength is 300 volts per mil.

- ❖ Tested to ASTM F712.
- ❖ Manufactured to ASTM F968 specifications.

Catalog No.	Description	Weight
C4060002	4 feet x 6 feet x 0.255"	30 lb./13.5 kg.

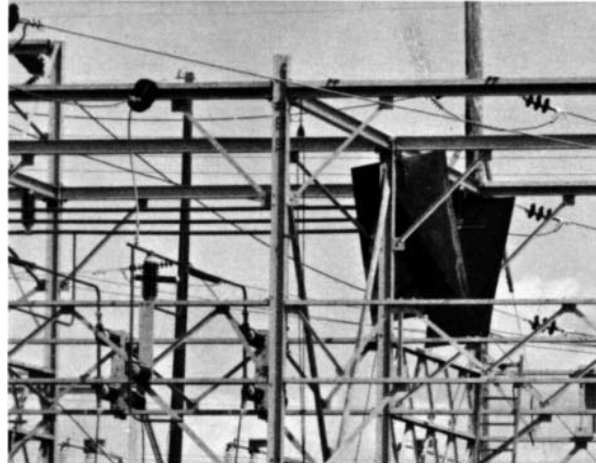

Insulator, Hardware, and Crossarm Covers

- Tested to ASTM F712 • Manufactured to ASTM F968 specifications

Pole Top Cover — 36.6 kV Ø-Ø

Made of high-impact orange ABS plastic, this cover is used to help prevent tie wires from making contact with the pole when tying or untying ridge construction. The cover will fit a pole top of up to 10 inches diameter with either single- or double-ridge pin construction. The maximum bolt length is 16 inches. The cover rests on top of the pole, covering 10½ inches of the pole top and 4½ inches of the ridge pin. By using the elastic cord furnished with the cover, the cover-up can be butted against the insulator to cover the ridge pin and pole top.

Catalog No.	Description	Weight
C4060097	Pole Top Cover	2½ lb./1.1 kg.



C4060097

Crossarm End Cover — 36.6 kV Ø-Ø

This cover is used to cover the end of the crossarm to help prevent tie wires from contacting the crossarm during tying and untying. This cover also helps prevent the lineman, who is rubber gloving, from contacting a ground potential while in contact with the conductor. The cover fits over the end of a crossarm up to 5 x 6 inches with either pin- or post-type insulator. Made of ABS orange plastic, slots may be cut in each side to provide passage for double-arming bolts.

Catalog No.	Description	Weight
C4060102	Crossarm End Cover	2½ lb./1.1 kg.



C4060102

Post Insulator Covers — 46 kV Ø-Ø & 25 kV Ø-Ø

Made of high-impact ABS plastic, split on each side forms a passage for the conductor. The bottom portion of the T-shape covers the insulator skirts; horizontal portion covers the conductor and hardware. The horizontal portion is flared at each end to interlock with Chance 36.6 or 46kV spiral conductor covers (see page 2407). The larger cover may be used on vertical and horizontal 46kV tie top and clamp top post insulators and Epoxirod® standoffs, pole tops and bi-unit assemblies.

Not for rubber glove installation above 34.5 kV.

C4060091	46kV Post Insulator Cover	3½ lb./1.6 kg.
C4060092	25kV Post Insulator Cover	3 lb./1.4 kg.

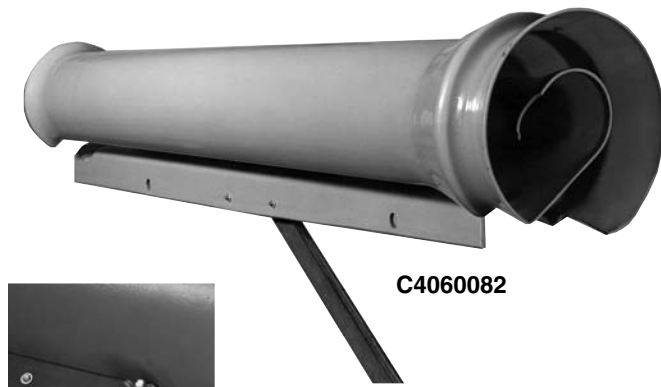

C4060091

C4060082

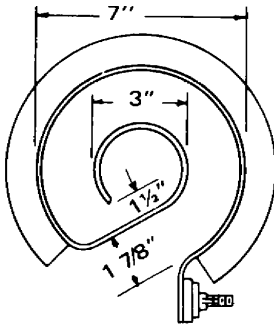
C4060040
Grip-All Adapter
 available as accessory,
 interchangeable with
 Epoxiglas handles.

Cross Section

15/36.6 kV units
 are slotted to fit over
 15 kV insulators.

Spiral Conductor Covers

15/36.6 kV and 46 kV Phase-to-Phase

- Tested to ASTM F712.
- Manufactured to ASTM F968 specifications.

A 4- or 6-foot long retractable Epoxiglas® handle provides for ease of installation from a bucket or platform, in single units or linked together. The bright-orange conductor cover is easy to install. It provides extra protection with a wide air space between two thicknesses of solid insulation. The cover is made of tough, durable ABS plastic. Overall length of each cover is 53 inches. All units can interlock with each other to make up a chain of guards. 15/36.6 kV units are formed on the ends to fit over most 15kV insulators, thus eliminating the need for an insulator cover. Each double-crossarm unit will fit over two 15kV pin-type insulators.

Catalog No.	Type of Fitting	Weight
-------------	-----------------	--------

46 kV Ø-to-Ø Units

C4060082	4' Epoxiglas handle	10½ lb./4.7 kg.
C40600826	6' Epoxiglas handle	11½ lb./5.2 kg.
C4060082GA	Grip-All Adapter	9½ lb./4.3 kg.

15/36.6 kV Ø-to-Ø Units for Single Crossarm

C4060083	4' Epoxiglas handle	9½ lb./4.1 kg.
C40600836	6' Epoxiglas handle	10½ lb./4.5 kg.
C4060083GA	Grip-All Adapter	8½ lb./3.6 kg.

15/36.6 kV Ø-to-Ø Units for Double Crossarm

C4060084	4' Epoxiglas handle	9 lb./4.1 kg.
C40600846	6' Epoxiglas handle	10 lb./4.5 kg.
C4060084GA	Grip-All Adapter	8 lb./3.6 kg.

Crossarm Cover Up

- ASTM Class 3 for 26.4kV phase-to-phase systems
- Telescopes to fit exact length requirements
- Custom fits with insert for pin insulator, without for post insulator

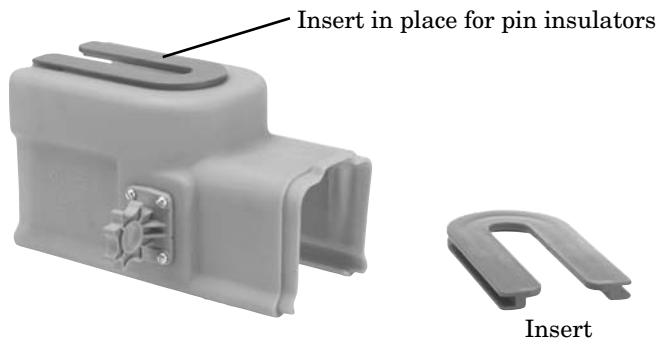

Grip-All adapter
permits handling
with clampstick.

Insert

For energized line work, this rigid cover up fits onto wood or steel crossarm sizes up to 3¾" x 4¾". The two-piece design telescopes from 13.1 to 20.9 inches, allowing easy adjustment to various lengths. With its removable insert in place, the cover gives the desired close fit on pin insulator construction. For the same type fit on post insulators, the insert simply is not used. An external hotstick adapter on the cover allows easy placement and removal by a Grip-All clampstick from most access angles.

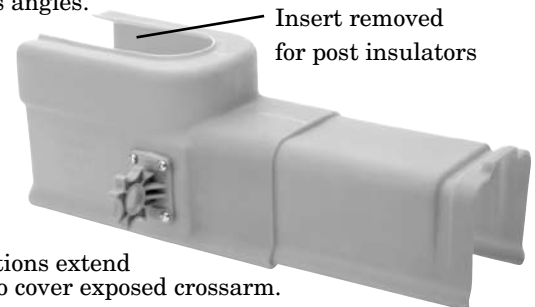

Sliding sections extend
or retract to cover exposed crossarm.

- Tested to ASTM F712
- Manufactured to ASTM F968 specifications
- Meets Class 3 requirements

Catalog No.	Description	Weight
C4060504	Crossarm Cover Up	2¼ lb. / 1 kg.

Crossarm Cover 36.6 kV Phase-to-Phase

- Tested to ASTM F712.
- Manufactured to ASTM F968 specifications.
- Meet Class 4 requirements.

Crossarm covers are used to help prevent tie wires from contacting the crossarm when tying and untying insulators.



The material used is the same high-dielectric polyethylene used for Chance conductor and insulator covers (shown below). The crossarm cover is designed for single- or double- arm construction, with slots provided for double-arming bolts. Flanges above the slots shield the ends of the double-arming bolts.

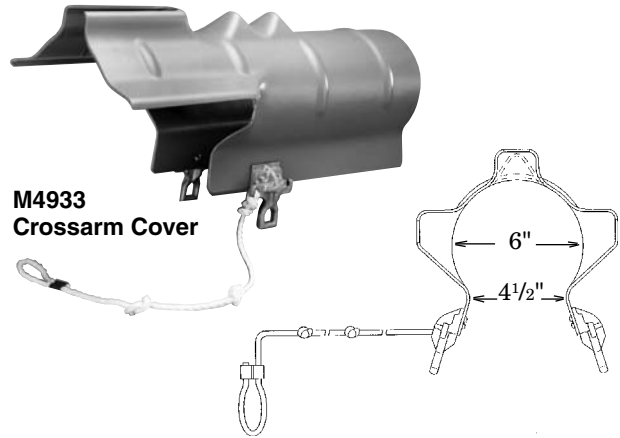

Catalog No.	Overall Length	Weight
M4933	Crossarm Cover, 24" Long	3 1/4 lb/1.5 kg.

Conductor and Insulator Covers 46 kV Phase-to-Phase



Two conductor covers lock together on a 13 kV line where an insulator cover is not required.



Two conductor covers lock with insulator cover on middle conductor of 34.5 kV sub-transmission lines.

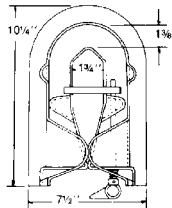

**M4931
Conductor Cover**

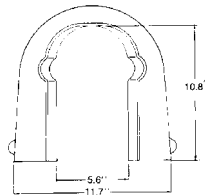

**C4060046
Insulator Cover**

These covers are made of high-dielectric polyethylene. The wax-like surface provides a natural self-cleaning action and resists the effects of greases and other contaminants. The bright-orange color gives a visible warning to those who are working close to the equipment.

Chance conductor and insulator covers are designed to help protect the lineman while working close to energized conductors. They are rated phase-to-phase for voltages through 46kV and can be easily installed with a Grip-All clampstick.

The conductor cover clips on and covers conductors up to 2 inches in diameter. A positive air gap is maintained by a special hanger system inside the cover. The conductor is locked in the hanger by a swinging latch that can be opened and closed with a hot stick.

The insulator cover is designed to be used in conjunction with

two conductor covers on insulators above 13kV. It fits over the insulator and locks with a conductor cover on each end. A polypropylene rope swings under the crossarm and hooks with a clampstick, thus helping to prevent the insulator cover from dislodging due to bumping or wind gusts.

Test Data

- Tested to ASTM F712.
- Manufactured to ASTM F968 specifications.

Electrical: Tests using conductor covers in conjunction with insulator covers provided 46kV phase-to-phase protection for normal working conditions.

Temperature: Will not soften or deform at 170° F. Will not embrittle at -50° F.

Catalog No.	Description	Capacity	Overall Length	Weight
M4931	Conductor Cover	Conductors through 1 3/4" diameter	5'	9 1/4 lb./4.2 kg.
C4060046	*Insulator Cover Set	Insulators through 10 1/2" diameter	22" to 34"	11 lb./5.0 kg.

*Consists of two pieces.

Rubber Insulating Blankets

- Meet ASTM Standard Specification D-1048
- For Class 4 Type II (ozone-resistant)

Performance-designed material

Chance Class 4 flexible blankets help protect workers from accidental contact with energized components during line maintenance.

Made of ozone/corona-resistant elastomer, these blankets offer excellent performance properties in accordance with ASTM Standard Specification D-1048. The special formulation exhibits superior resistance to long-term aging/checking and will retain its high-visibility orange color.

Versatile protection, maximum rating

Flexible to cover many irregular shapes, rubber blankets typically are used with conductor covers (flexible or rigid) on deadends, apparatus, secondary racks, poletop pins and crossarms.

Because they are Class 4 (highest rating in the industry) and Type II (ozone-resistant), Chance blankets may be used in applications which require lower class or type.

Chance blankets are designed with perimeter eyelets to accept Chance button C4060532 and most other buttons existing in the field. The 1.5"-diameter center hole in Chance slotted blankets will fit easily around common hardware.

Ordering Information

- Class 4
- Proof Tested at 40kV AC rms
- Maximum Use: 36kV Ø-Ø



Solid Blankets

Catalog No.	Description	Weight
C4060346	36" x 36", 6 eyelets	8¼ lb. (3.7 kg.)

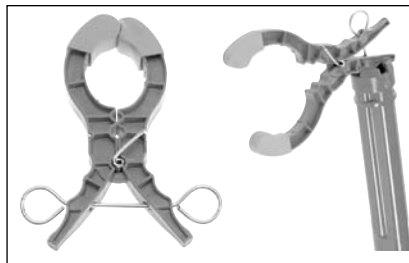

Hot Stick Clamp
Catalog No.
C4060531
Eyes and special handle shape for easy placement by clampstick

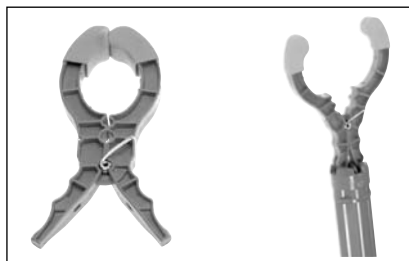

Rubber Glove Clamp
Cat. No. C4060530
Special handle shape also fits clampstick for easy placement



Slotted Blankets

Catalog No.	Description	Weight
C4060348	36" x 36", 28 eyelets	8¼ lb. (3.7 kg.)

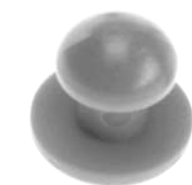

Cat. No. C4060532

Accessories

Catalog No.	Description	Weight
C4060530	Clamp Pin, Rubber Glove	1 lb. (.45 kg.)
C4060531	Clamp Pin, Hot Stick	1 lb. (.45 kg.)
C4060532	Button, Rubber Blanket	1/8 lb. (.06 kg.)
T4060108	*Storage Tube 40" x 6"	6¾ lb. (7 kg.)
C4032998	*Storage Cannister, no handle	6 lb. (2.7 kg.)
C4032999	*Storage Cannister w/handle	7⅝ lb. (3.43 kg.)

*For details, see Catalog Section 2500.



Short-Lip Flexible Line Hose

Choices of ratings & sizes: • 17 kV, Class 2, 1 1/4"-dia. • 26.5 kV, Class 3, 1 1/2"-dia.

Low weight, high performance

Much lighter in weight than other flexible dielectric cover-up, Chance Line Hose helps protect workers from accidental contact with conductors.

In accordance with ASTM D 1050-90, Chance ozone/corona-resistant thermoplastic elastomer offers excellent performance properties. It does not absorb water.

Easy to handle and place

The outer lip peels back with ease to open and start onto a conductor from either end. With a push at the other end, the full length slides on as the lips zip closed around the conductor. To remove each piece, open one end and strip the remainder off the conductor.

Two color choices

For color-coding, some utilities assign orange and white hose to different applications. To retain its original color, Chance hose has superior resistance to long-term ageing/checking.

• Orange and White color choices

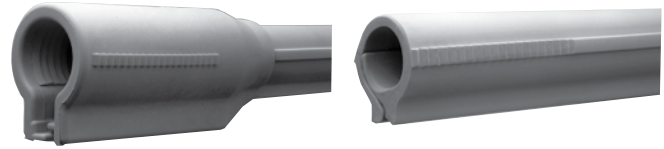

Serrated external ribs permit inside long arm on flexible hoods made by others. Resilient lips overlap to surround conductor.

Parallel grooves inside coupler match and grip the 20 serrations (1/4" each) in outside ribs. All serrated sections measure 5" long. Coupler overlaps 6" onto plain end.

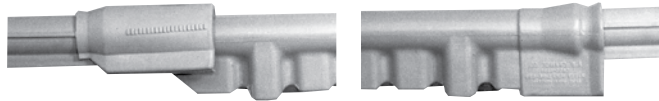

Interchangeable with other flexible cover-up brands, Chance Line Hose also engages Chance rigid-type insulator hoods, deadend covers and lineguards (rated for 25kV phase-to-phase, see Catalog Pages 2402 and 2403).

Short-Lip Line Hose — Type III — Ozone-Resistant Meets ASTM Standard Specification D 1050



ORANGE COLOR — Style A — Plain, Both Ends

Catalog No.	Length	Weight
1 1/4" Inside Diameter — Max. Use Ø - Ø: 17 kV — Class 2, Proof Tested at 20 kV AC rms		
C4060294	3 ft.	2.27 lb./1.0 kg.
C4060295	4 1/2 ft.	3.41 lb./1.6 kg.
C4060296	6 ft.	4.55 lb./2.1 kg.

ORANGE COLOR — Style B — Coupler, One End

Catalog No.	Length	Weight
1 1/4" Inside Diameter — Max. Use Ø - Ø: 17 kV — Class 2, Proof Tested at 20 kV AC rms		
C4060304	3 ft.	3.17 lb./1.4 kg.
C4060305	4 1/2 ft.	4.31 lb./1.9 kg.
C4060306	6 ft.	5.44 lb./2.5 kg.

1 1/2" Inside Diameter — Max. Use Ø - Ø: 26.5 kV — Class 3, Proof Tested at 30 kV AC rms

C4060297	3 ft.	3.11 lb./1.4 kg.
C4060298	4 1/2 ft.	4.66 lb./2.1 kg.
C4060299	6 ft.	6.22 lb./2.8 kg.

C4060307	3 ft.	4.09 lb./1.9 kg.
C4060308	4 1/2 ft.	5.64 lb./2.6 kg.
C4060309	6 ft.	7.2 lb./3.3 kg.

WHITE COLOR — Style A — Plain, Both Ends

Catalog No.	Length	Weight
1 1/4" Inside Diameter — Max. Use Ø - Ø: 17 kV — Class 2, Proof Tested at 20 kV AC rms		
C4060394	3 ft.	2.27 lb./1.0 kg.
C4060395	4 1/2 ft.	3.41 lb./1.6 kg.
C4060396	6 ft.	4.55 lb./2.1 kg.

WHITE COLOR — Style B — Coupler, One End

Catalog No.	Length	Weight
1 1/4" Inside Diameter — Max. Use Ø - Ø: 17 kV — Class 2, Proof Tested at 20 kV AC rms		
C4060404	3 ft.	3.17 lb./1.4 kg.
C4060405	4 1/2 ft.	4.31 lb./1.9 kg.
C4060406	6 ft.	5.44 lb./2.5 kg.

1 1/2" Inside Diameter — Max. Use Ø - Ø: 26.5 kV — Class 3, Proof Tested at 30 kV AC rms

C4060397	3 ft.	3.11 lb./1.4 kg.
C4060398	4 1/2 ft.	4.66 lb./2.1 kg.
C4060399	6 ft.	6.22 lb./2.8 kg.

C4060407	3 ft.	4.09 lb./1.9 kg.
C4060408	4 1/2 ft.	5.64 lb./2.6 kg.
C4060409	6 ft.	7.2 lb./3.3 kg.

Extended-Lip Flexible Line Hose

36 kV, Class 4, 1½"-diameter

Low weight, high performance

As much as 25 percent lighter in weight than other Class 4 flexible cover-up, Chance Line Hose helps protect workers from accidental contact with conductors.

In accordance with ASTM D 1050-90, Chance ozone/corona-resistant thermoplastic elastomer offers excellent performance properties. To retain high-visibility orange color, the special formulation exhibits superior resistance to long-term aging/checking. It does not absorb water.

The dielectric cover-up system consists of a separate coupler and three popular hose lengths. This permits hoses to join to cover straight runs or to flex to fit contours at bends and angles. Shorter sections may be cut on site from standard lengths to custom-fit taps, jumpers and like wires.



PLACE APPLICATOR THIS SIDE

For installation by hot-line tools, design provides a flat area debossed full length to accept special applicator tools (see Catalog Section 2100).

Easy to handle and place

Rubber gloves or hot-line tools may be used to apply Chance Class 4 Line Hose.

In addition to lightweight, the balanced material composition in Chance line hose also gives it pliability. This makes it easy to put on, couple, relocate and remove, unencumbered even when wearing leather protectors over rubber gloves.

The outer lip peels back with ease to open and start onto a conductor from either end. With a push at the other end, the full length slides on as the lips zip closed around the conductor.

So the hose can readily insert into the coupler, Chance bevels the serrations on the side ribs. The vertical serrations resist withdrawal from the coupler.

Two or more coupled sections stay joined when drawn along on the conductor and positioned as a unit. The rubber-like material slides readily by hand yet resists creep or slippage when placed. To remove each piece, open one end and strip the remainder off the conductor.



Coupler also can join sections Chance 1½"-diameter short-lip Class 3 hose for 26.5 kV phase-to-phase maximum use.



Long lips provide flashover distance to permit use on systems through 36 kV phase-to-phase.

Interchangeable with other brands of extended-lip hose, Chance Class 4 flexible cover-up joins with separate coupler.



Parallel grooves inside the coupler match and grip the 28 serrations (¼" each) in Class 4 hose ribs. All serrated sections on Class 4 hose measure 7 inches long. Coupler overlaps 5¼ inches onto hose when engaged.

Ordering Information

Meets ASTM Standard Specification D 1050 for Type III — Ozone Resistant Class 4, Proof Tested at 40 kV AC rms Maximum Use, Phase-to-Phase: 36 kV



Hose — Style C - Plain, Both ends — 1½" I.D.

Catalog No.	Length	Weight
C4060341	3 feet	4½ lb./2 kg.
C4060342	4½ feet	6¾ lb./3 kg.
C4060343	6 feet	9 lb./4 kg.

Coupler

C4060340	10½ inches	1½ lb./0.7 kg.
----------	------------	----------------



Arc-Suppression Blankets • for shields against electrical fault blasts (Not Electrically Insulated)

Heavy-duty protection in lightweight package

Two synthetic fabrics are combined in the ArcSafe™ Suppression Blanket from Workrite (Your Uniform for Life Company). Both space-age fabrics are aramid-fiber types. The inner layer is Kevlar® and the outer is NOMEX® III.

Kevlar is the same aramid fiber used in combat helmets and body armor. Flame-resistant NOMEX III is used as the cover to protect the Kevlar core from ultraviolet degradation.

Because the blankets consist of thin layers, ArcSafe blankets offer unrivaled portability and are extremely easy to maneuver in confined spaces. They weigh only 1/5 pound per square foot (5/8 kg. per m²).



Tested successfully at 42,000 amps fault current

ArcSafe was subjected to fault-current testing at Chance laboratories. ArcSafe was placed over a small section of 2/0 copper cable that was faulted to ground, simulating a cable or splice failure. The maximum fault current generated was 42,432 amps for a duration of 13 cycles.

Other than black deposits, ArcSafe experienced no damage and provided total fault-blast containment.

Kevlar® and NOMEX® are DuPont registered trademarks for its aramid fibers. Only DuPont makes Kevlar and NOMEX.

Warning: The ArcSafe Suppression Blanket has been developed by leading industrial and safety engineers, and Workrite believes it to be the best available for its intended purpose. However, explosions and blasts due to electrical faulting may be erratic and unpredictable, and we do not claim that ArcSafe offers total protection. It improves the chances of a worker's survivability in a life-threatening incident. In addition, ArcSafe is NOT classified as "Electrically Insulated" and must NEVER be used as such. Before using this or any protective product, please avail yourself of all information concerning its use.



Applications and conforming to OSHA law

When draped or loosely wrapped over a defective cable or splice, ArcSafe provides a protective shield for exposed workers. Velcro® straps sewn on the back help keep ArcSafe where positioned.

ArcSafe blankets meet or exceed OSHA requirements for manhole protection.

Beginning in 1991, OSHA mandates that if cables in manholes appear defective . . .

“ . . . and cannot be de-energized due to service load conditions, employees may enter the manhole provided they are protected from the possible effects of a failure by shields or other devices that are capable of containing the adverse effects of a fault in the joint.” [29 CFR Part 1910.269(t)(7)]



ArcSafe™ Arc-Suppression Blankets

Catalog No.	Size	Weight
C4060452	4 ft. x 5 ft. (1.2 x 1.5 meters)	4 lb./1.8 kg.
C4060453	4 ft. x 8 ft. (1.2 x 2.4 meters)	6½ lb./2.9 kg.